

# Product data sheet

## Characteristics

# XUZASK004

Fixing bracket, Photoelectric sensors XU,  
accessory for sensor, XUK laser + TOF, angle  
fine adjustable

Product availability: Non-Stock - Not normally stocked in distribution facility

Price\*: 110.00 USD



### Main

Range of Product	Telemecanique Photoelectric sensors XU
Accessory / separate part category	Mounting and fixing accessory
Accessory / Separate Part Type	Fixing bracket
Product or Component Type	Fixing bracket
Accessory / separate part destination	Compact sensor 50 x 50 mm
Material	Metal

### Complementary

Product Compatibility	XUK8LAPPNM12 XUK9LAPSMM12 XUK2LAKSMM12T XUK5LAPSMM12 XUK8TAKSMM12 XUK8TAKDMM12 XUK2LAPSMM12R XUK9TAH2MM12 XUK8TAE1MM12 XUK8TAE2MM12
Net Weight	0.53 Lb(US) (0.24 kg)

### Ordering and shipping details

Category	22499 - SENSORS ACCESSORIES
Discount Schedule	DS2
GTIN	03389119621311
Nbr. of units in pkg.	1
Package weight(Lbs)	4.30 Oz (122 g)
Returnability	Yes
Country of origin	DE

## Packing Units

Unit Type of Package 1	PCE
Package 1 Height	2.17 In (5.5 cm)
Package 1 width	3.90 In (9.9 cm)
Package 1 Length	2.80 In (7.1 cm)
Unit Type of Package 2	S01
Number of Units in Package 2	25
Package 2 Weight	7.22 Lb(US) (3.275 kg)
Package 2 Height	5.91 In (15 cm)
Package 2 width	5.91 In (15 cm)
Package 2 Length	15.75 In (40 cm)

## Offer Sustainability

California proposition 65	WARNING: This product can expose you to chemicals including: Diisononyl phthalate (DINP), which is known to the State of California to cause cancer, and Diisodecyl phthalate (DIDP), which is known to the State of California to cause birth defects or other reproductive harm. For more information go to <a href="http://www.P65Warnings.ca.gov">www.P65Warnings.ca.gov</a>
REACH Regulation	<a href="#">REACH Declaration</a>
REACH free of SVHC	Yes
EU RoHS Directive	Pro-active compliance (Product out of EU RoHS legal scope) <a href="#">EU RoHS Declaration</a>
Toxic heavy metal free	Yes
Mercury free	Yes
RoHS exemption information	<a href="#">Yes</a>

## Contractual warranty

Warranty	18 months
----------	-----------

Dimensions

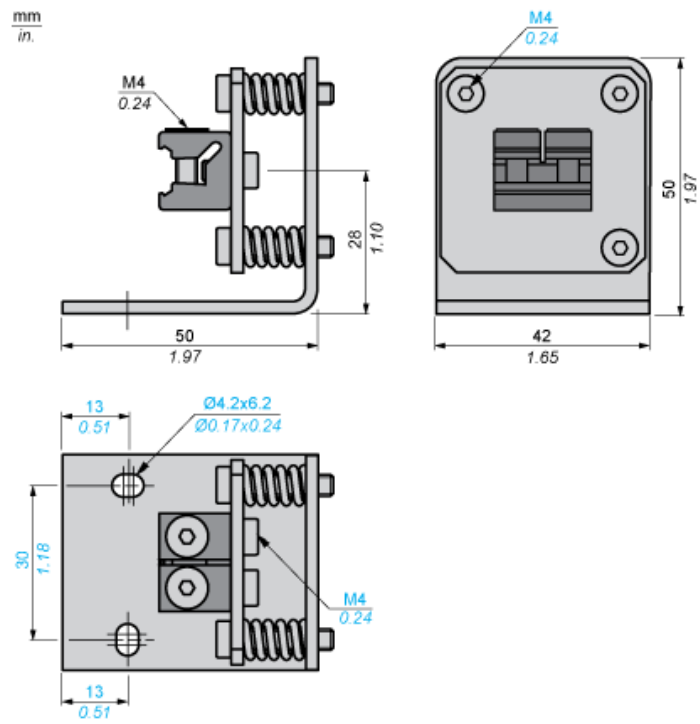

Mounting

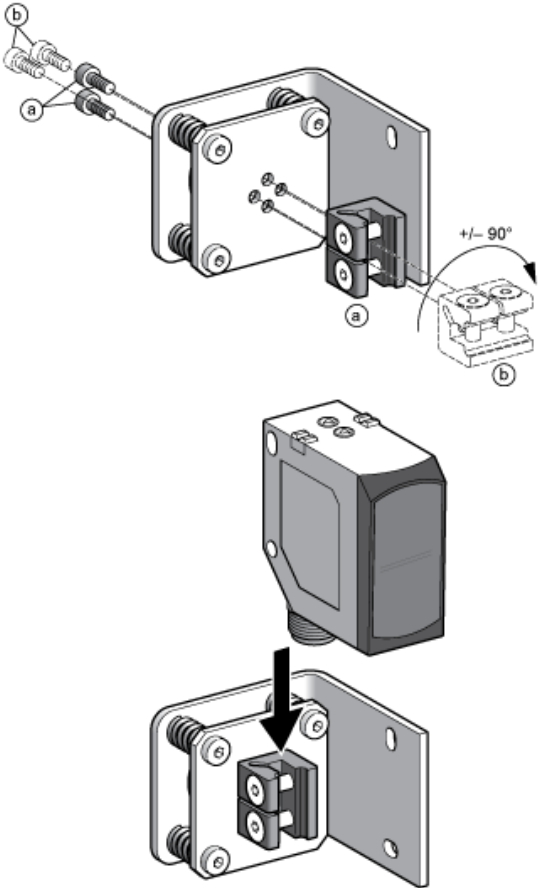

Product Life Status : Commercialised